

PI

PU



Pulse Valve

Opening: 20~50ms ,
Closing: 100~400ms

Ambient Temperature.. : -15~50°C

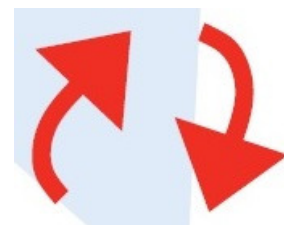
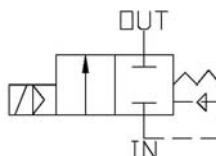

ISO 9001 Certificate



PI
PU

SPECIFICATIONS: Aluminum Die Casting Body N.C., for Air.

Type	CODE (PIPE)	Orifice mm	Seal	Coil #	Working Pressure bar	Temp. °C
PI	20(3/4")	25	NBR	3、2E	0.5~7	-5~80
	25(1")	30				
	40(1-1/2")	45				
	50(2")	57				
	65(2-1/2")	72				
	80(3")	80				
PU	25(1")	30				
	40(1-1/2")	45				

Coil NO.#	#3	#2E
AC (VA)	8.0	4.8
Final Temp. °C	60	50
DC (W)	6.8	5.2
Final Temp. °C	73	55

TYPE INDICATION:

TYPE ——— CODE ——— COIL# ——— PLUG

PI 20 (3 / 4 ") □ : #3 □ : STADARD
 25 (1 ") E : EExmIIT4 D : LED
 40 (1 - 1 / 2 ") G : 1 / 2 " NPT
 50 (2 ")
 65 (2 - 1 / 2 ")
 80 (3 ")

TYPE ——— CODE ——— COIL# ——— PLUG

PU 25 (1 ") □ : #3 □ : STADARD
 40 (1 - 1 / 2 ") E : EExmIIT4 D : LED
 G : 1 / 2 " NPT

DIMENSIONS:

TYPE	CODE	L	L'	H	H'	W	NT. kg
PI	20	90	52	130	108	75	0.7
	25	90	52	130	108	75	0.7
	40	140	72	178	148	137	1.5
	50	181	95	228	183	170	3.1
	65	181	95	228	183	170	3.0
	80	215	118	264	206	195	2.6
PU	25	114	77	168	99	75	1.07
	40	169	100	210	139	137	2.28

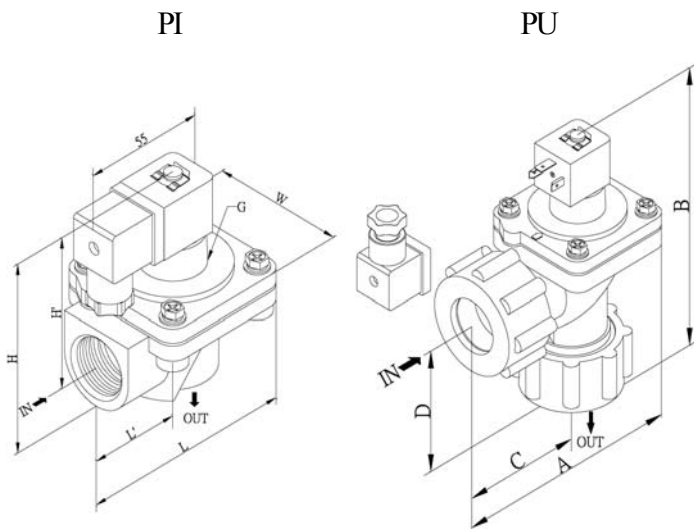

TYPE INDICATION :

Example : PI40-D-DC24V

Type PI 、 1-1/2" PIPE 、 LED Plug 、 DC24V

Connexion Developments Ltd

Unit 3 Rainbow Court, Armstrong Way, Yate, Bristol, BS37 5NG, England
 Tel: 0800 808 7799 Int: +44 1454 334990 Fax: 0800 808 7700 Int: +44 (0) 1454 326390
 Company Registered: 03502257 VAT No: 712906844

sales@solenoid-valves.com

www.solenoid-valve.world