

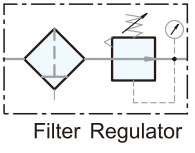

Symbol



Features

1. Remove water and particle effectively.
2. Compact size with effective air service.
3. 40µm and 5µm filter element are easily interchangeable and replaceable.
4. Accurate and easy pressure setting.

How to order

FR500C	02	N	C	B	H
Miniature Filter Regulator	Port size	Thread	Filtration	Gauge type	Drain
	01 : 1/8"(option) 02 : 1/4"	Blank :G N :NPT R :Rc	PE Blank :5µm C :40µm Sintered brass S :5µm T :40µm	Blank : Circle B : Square	Blank :Semi-auto drain H :Manual drain D :Auto drain

Please contact our sales for non-relieving type.
*For non-relieving type, the secondary pressure is not allowed to be exhausted when it is higher than setting pressure.

Specifications

Model	FR500C-01	FR500C-02
Port size	1/8" (option)	1/4"
Fluid	Compressed air	
Regulator construction	Piston	
Body material	Aluminum die-cast	
Bowl material	Polycarbonate (Standard)	
Filtration	PE: 5µm (Standard), 40µm (Option); Sintered brass(Option):5µm, 40µm	
Operating pressure range	0.5 ~ 9.9 kgf/cm ²	
Max. inlet pressure	12 kgf/cm ²	
Max. flow rate l/min (ANR)	1800	1880
Ambient temperature	-10°C ~ 60°C	
Filter bowl capacity	40cc	
Standard drain	Semi-auto drain (Drains below 0.5kgf/cm ²)	
Net weight	365g	
Accessories	Mounting bracket set, Plug	
Option	Gauge plate, Mounting nut	

Dimensions

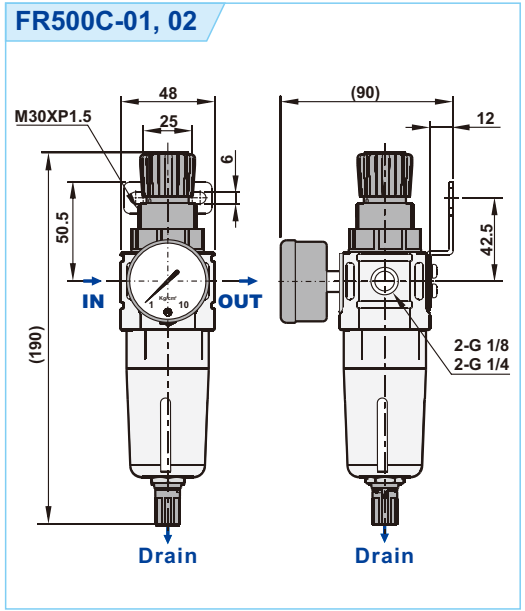

Flow chart

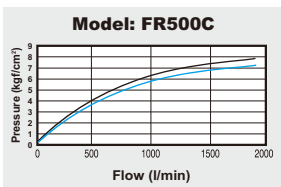

Note:

X axis: Flow (l/min)
Y axis: Pressure (kgf/cm²)
Blue line (P0) = Outlet pressure
Black line (P1) = Inlet pressure
P1-P0= Pressure range